



Standard Test Method for Index Puncture Resistance of Geomembranes and Related Products¹

This standard is issued under the fixed designation D4833/D4833M; the number immediately following the designation indicates the year of original adoption or, in the case of revision, the year of last revision. A number in parentheses indicates the year of last reapproval. A superscript epsilon (ϵ) indicates an editorial change since the last revision or reapproval.

This standard has been approved for use by agencies of the U.S. Department of Defense.

^{ε1} NOTE—Units information was editorially corrected in June 2013.

1. Scope

1.1 This test method is used to measure the index puncture resistance of geomembranes and related products.

1.2 The use of Test Method D4833/D4833M may be inappropriate for testing some woven geotextiles or related products which have large openings, such as geonets and geogrids.

1.3 It is recommended that geotextile and geotextile related products be tested using Test Method [D6241](#).

1.4 The values stated in either SI units or inch-pound units are to be regarded separately as standard. The values stated in each system may not be exact equivalents; therefore, each system shall be used independently of the other. Combining values from the two systems may result in non-conformance with the standard.

1.5 *This standard does not purport to address all of the safety concerns, if any, associated with its use. It is the responsibility of the user of this standard to establish appropriate safety and health practices and determine the applicability of regulatory limitations prior to use.*

2. Referenced Documents

2.1 ASTM Standards:²

[D76/D76M Specification for Tensile Testing Machines for Textiles](#)

[D123 Terminology Relating to Textiles](#)

[D1776 Practice for Conditioning and Testing Textiles](#)

[D2905 Practice for Statements on Number of Specimens for](#)

¹ This test method is under the jurisdiction of ASTM Committee [D35](#) on Geosynthetics and is the direct responsibility of Subcommittee [D35.01](#) on Mechanical Properties.

Current edition approved May 1, 2013. Published June 2013. Originally approved in 1988. Last previous edition approved in 2007 as [D4833-07](#). DOI: 10.1520/D4833_D4833M-07R13E01.

² For referenced ASTM standards, visit the ASTM website, www.astm.org, or contact ASTM Customer Service at service@astm.org. For *Annual Book of ASTM Standards* volume information, refer to the standard's Document Summary page on the ASTM website.

[Textiles \(Withdrawn 2008\)](#)³

[D4354 Practice for Sampling of Geosynthetics and Rolled Erosion Control Products\(RECPs\) for Testing](#)

[D4439 Terminology for Geosynthetics](#)

[D6241 Test Method for Static Puncture Strength of Geotextiles and Geotextile-Related Products Using a 50-mm Probe](#)

3. Terminology

3.1 Definitions:

3.1.1 *atmosphere for testing geotextiles, n*—air maintained at a relative humidity of $65 \pm 5\%$ and a temperature of $21 \pm 2^\circ\text{C}$ [$70 \pm 4^\circ\text{F}$].

3.1.2 *geomembrane, n*—very low permeability synthetic membrane liners or barriers used with any geotechnical engineering related material so as to control fluid migration in a man-made project, structure, or system.

3.1.3 *index test, n*—a test procedure which may contain a known bias but which may be used to establish an order for a set of specimens with respect to the property of interest.

3.1.4 *puncture resistance (F), n*—the inherent resisting mechanism of the test specimen to the failure by a penetrating or puncturing object.

3.2 For definitions of other terms relating to geosynthetics used in this standard, refer to Terminology [D4439](#).

4. Summary of Test Method

4.1 A test specimen is clamped without tension between circular plates of a ring clamp attachment secured in a tensile testing machine. A force is exerted against the center of the unsupported portion of the test specimen by a solid steel rod attached to the load indicator until rupture of the specimen occurs. The maximum force recorded is the value of puncture resistance of the specimen.

³ The last approved version of this historical standard is referenced on www.astm.org.

5. Significance and Use

5.1 This test method is an index test for determining the puncture resistance of geomembranes and related products. The use of this test method is to establish an index value by providing standard criteria and a basis for uniform reporting.

5.2 This test method is considered satisfactory for acceptance testing of commercial shipments of geomembranes and related materials since the test method has been used extensively in the trade for acceptance testing.

5.2.1 In case of a dispute arising from differences in reported test results when using this test method for acceptance testing of commercial shipments, the purchaser and the supplier should conduct comparative tests to determine if there is a statistical bias between their laboratories. Competent statistical assistance is recommended for the investigation of bias. As a minimum, the two parties should take a group of test specimens that are as homogeneous as possible and that are

from a lot material of the type in question. The test specimens should then be randomly assigned in equal numbers to each laboratory for testing. The average results from the two laboratories should be compared using Student's *t*-test for unpaired data and an acceptable probability level chosen by the two parties before the testing is begun. If a bias is found, either its cause must be found and corrected or the purchaser and the supplier must agree to interpret future test results in the light of the known bias.

6. Apparatus

6.1 *Tensile/Compression Testing Machine*, of the constant-rate-of extension (CRE) type, with autographic recorder conforming to the requirements of Specification **D76/D76M**. See **Fig. 1**.

6.2 *Ring Clamp Attachment*, consisting of concentric plates with an open internal diameter of 45 ± 0.025 mm [$1.772 \pm$

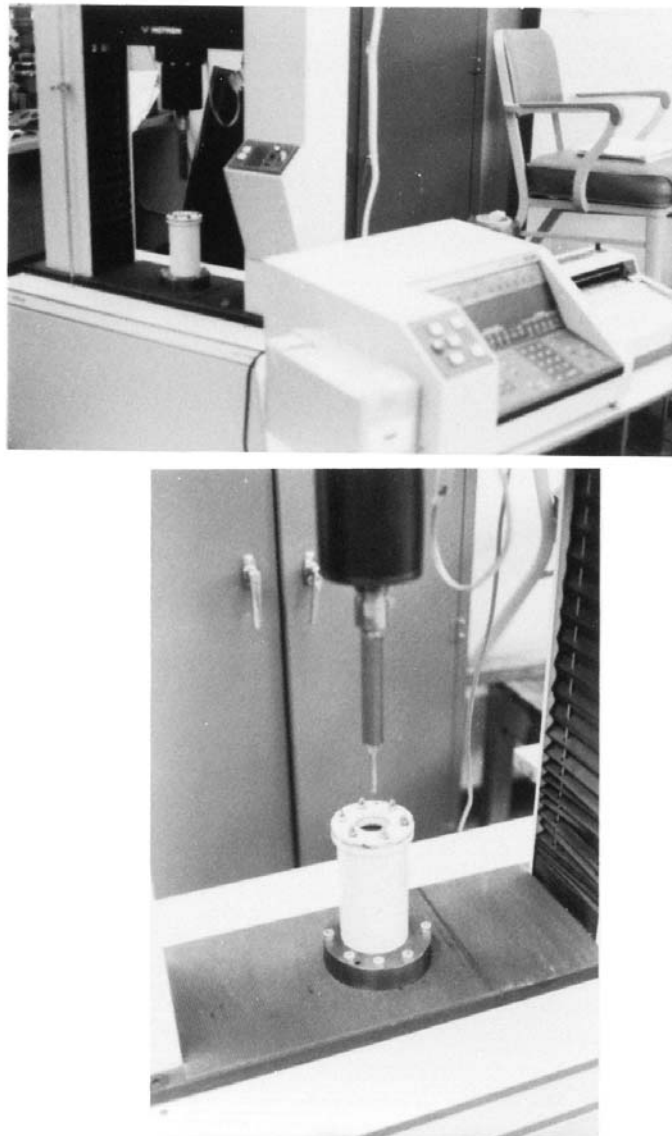

FIG. 1 Photographs of Test Setup and Fixture

0.001 in.], capable of clamping the test specimen without slippage. A suggested clamping arrangement is shown in Fig. 1 and Fig. 2. The external diameter is to be a minimum of 100 [3.937]. The diameter of the six holes used for securing the ring clamp assembly is suggested to be 8 mm [0.135 in.] and equally spaced at a radius of 37 mm [2.95 in.]. The surfaces of these plates can consist of grooves with O-rings or coarse sandpaper bonded onto opposing surfaces.

6.3 *Solid Steel Rod*, with a diameter of 8 ± 0.1 mm [0.315 \pm 0.004 in.] having a flat end with a $45^\circ = 0.8$ mm [0.315 in.] chamfered edge contacting the test specimen's surface. See Fig. 1 and Fig. 3.

7. Sampling

7.1 *Lot Sample*—Divide the product into lots and take the lot sample as directed in Practice D4354.

7.2 *Laboratory Sample*—For the laboratory sample, take a swatch extending the full width and of sufficient length along the selvage, from each sample roll so that the requirements of 7.3 and 8.1 can be met. Take a sample that will exclude material from the outer wrap and inner wrap around the core unless the sample is taken at the production site, then inner and outer wrap material may be used.

7.3 *Test Specimens*—Select from the laboratory sample the number of specimens directed in Section 8. Minimum specimen diameter is 100 mm [4 in.] to facilitate clamping. Space the specimens along a diagonal on the unit of the laboratory sample. Take no specimens nearer the selvage or edge of the geotextile sample than $1/10$ the width of the geotextile sample.

8. Number of Specimens

8.1 *Reliable Estimate of v*—When there is a reliable estimate of v based on extensive past records for similar materials tested in the user's laboratory, calculate the number of specimens per unit in the laboratory sample using Eq 1:

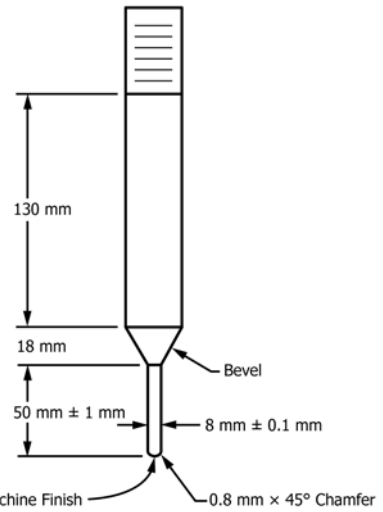

FIG. 3 Test Probe Detail (Not to Scale)

$$n = (tv/a)^2 = (tv)^2/36 \tag{1}$$

where:

- n = number of specimens (rounded upward to a whole number),
- v = reliable estimate of the coefficient of variation for individual observations on similar materials in the user's laboratory under conditions of single-operator precision,
- t = value of Student's test for two-sided limits (see Table 1) a 95 % probability level, and the degrees of freedom associated with the estimate of v , and
- A = 6 % of the average, the value of the allowable variable.

8.2 *No Reliable Estimate of v*—When there is no reliable estimate of v in the user's laboratory, specify the fixed number of 5 specimens for geomembranes per swatch in the laboratory sample and 5 for other related products. This number of

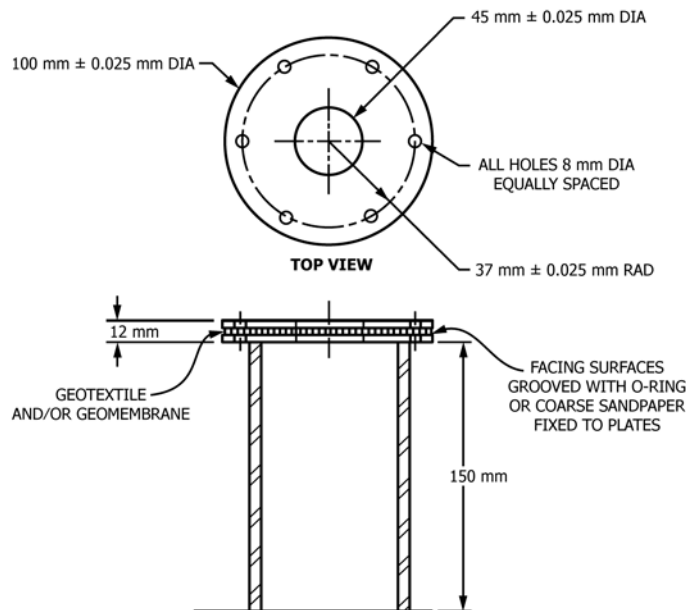

FIG. 2 Test Fixture Detail (Not to Scale)

TABLE 1 Values of Student's *t* for Two-Sided Limits and the 95 % Probability^A

df	<i>t</i> .025	df	<i>t</i> .025	df	<i>t</i> .025
1	12.706	11	2.201	21	2.080
2	4.303	12	2.179	22	2.074
3	3.182	13	2.160	23	2.069
4	2.776	14	2.145	24	2.064
5	2.571	15	2.131	25	2.060
6	2.447	16	2.120	26	2.056
7	2.365	17	2.110	27	2.052
8	2.306	18	2.101	28	2.048
9	2.262	19	2.093	29	2.045
10	2.228	20	2.086	inf.	1.960

^A Values in this table were calculated using Hewlett Packard HP 67/97 Users' Library Programs 03848D, "One-Sided and Two-Sided Critical Values of Student's *t*" and 00350D, "Improved Normal and Inverse Distribution." For values at other than the 95 % probability level, see published tables of critical values of Student's *t* in any standard statistical text. Further use of this table is defined in Practice D2905.

specimens is calculated using $\nu = 10\%$ of the average, which is a somewhat larger value of ν than is usually found in practice. When a reliable estimate of ν for the user's laboratory becomes available, Eq 1 will usually require fewer than 15 specimens per swatch in the laboratory sample.

9. Conditioning

9.1 Bring the specimens to moisture equilibrium in the atmosphere for testing (3.1). Equilibrium is considered to have been reached when the increase in the mass of the specimen, in successive weighings made at intervals of not less than 2 h, does not exceed 0.1 % of the mass of the specimen.

10. Procedure

10.1 Select the load range of the tensile/compression testing machine such that the rupture occurs between 10 and 90 % of the full-scale load.

10.2 Center and secure the specimen between the holding plates ensuring that the test specimen extends to or beyond the outer edges of the clamping plates.

10.3 Test at a machine speed of 300 ± 10 mm [12 in. \pm ½ in.]/min until the puncture rod completely ruptures the test specimen.

NOTE 1—The rate of testing specified is not an indication of the performance of the specimen for its end use.

10.4 Read the puncture resistance from the greatest force registered on the recording instrument during the test. For the testing of composite geomembrane materials, there may be a double peak. If so, the initial value should be reported even if the second peak is higher than the first one.

11. Calculation

11.1 Calculate the average puncture resistance and standard deviation for all tests as read directly from the recording instrument.

12. Report

12.1 State that the specimens were treated as directed in Test Method D4833/D4833M.

12.2 Report on the following information:

12.2.1 The method of holding the test specimen in the clamping device.

12.2.2 The average puncture resistance of the specimens tested.

12.2.3 The coefficient of variation (if known) and standard deviation for each group of specimens.

12.2.4 The variation, if any, from the described test method.

13. Precision and Bias

13.1 *Precision*—The precision of the procedure in this test method for measuring the puncture resistance of geotextiles, geomembranes, and related materials is being established.

13.2 *Bias*—The procedure in this test method for measuring the puncture resistance of geomembranes and related materials has no bias because the value of that property can be defined only in terms of a test method.

14. Keywords

14.1 geomembranes; puncture; puncture resistance

ASTM International takes no position respecting the validity of any patent rights asserted in connection with any item mentioned in this standard. Users of this standard are expressly advised that determination of the validity of any such patent rights, and the risk of infringement of such rights, are entirely their own responsibility.

This standard is subject to revision at any time by the responsible technical committee and must be reviewed every five years and if not revised, either reapproved or withdrawn. Your comments are invited either for revision of this standard or for additional standards and should be addressed to ASTM International Headquarters. Your comments will receive careful consideration at a meeting of the responsible technical committee, which you may attend. If you feel that your comments have not received a fair hearing you should make your views known to the ASTM Committee on Standards, at the address shown below.

This standard is copyrighted by ASTM International, 100 Barr Harbor Drive, PO Box C700, West Conshohocken, PA 19428-2959, United States. Individual reprints (single or multiple copies) of this standard may be obtained by contacting ASTM at the above address or at 610-832-9585 (phone), 610-832-9555 (fax), or service@astm.org (e-mail); or through the ASTM website (www.astm.org). Permission rights to photocopy the standard may also be secured from the Copyright Clearance Center, 222 Rosewood Drive, Danvers, MA 01923, Tel: (978) 646-2600; http://www.copyright.com/